

# PRODUCT SPECIFICATION SHEET

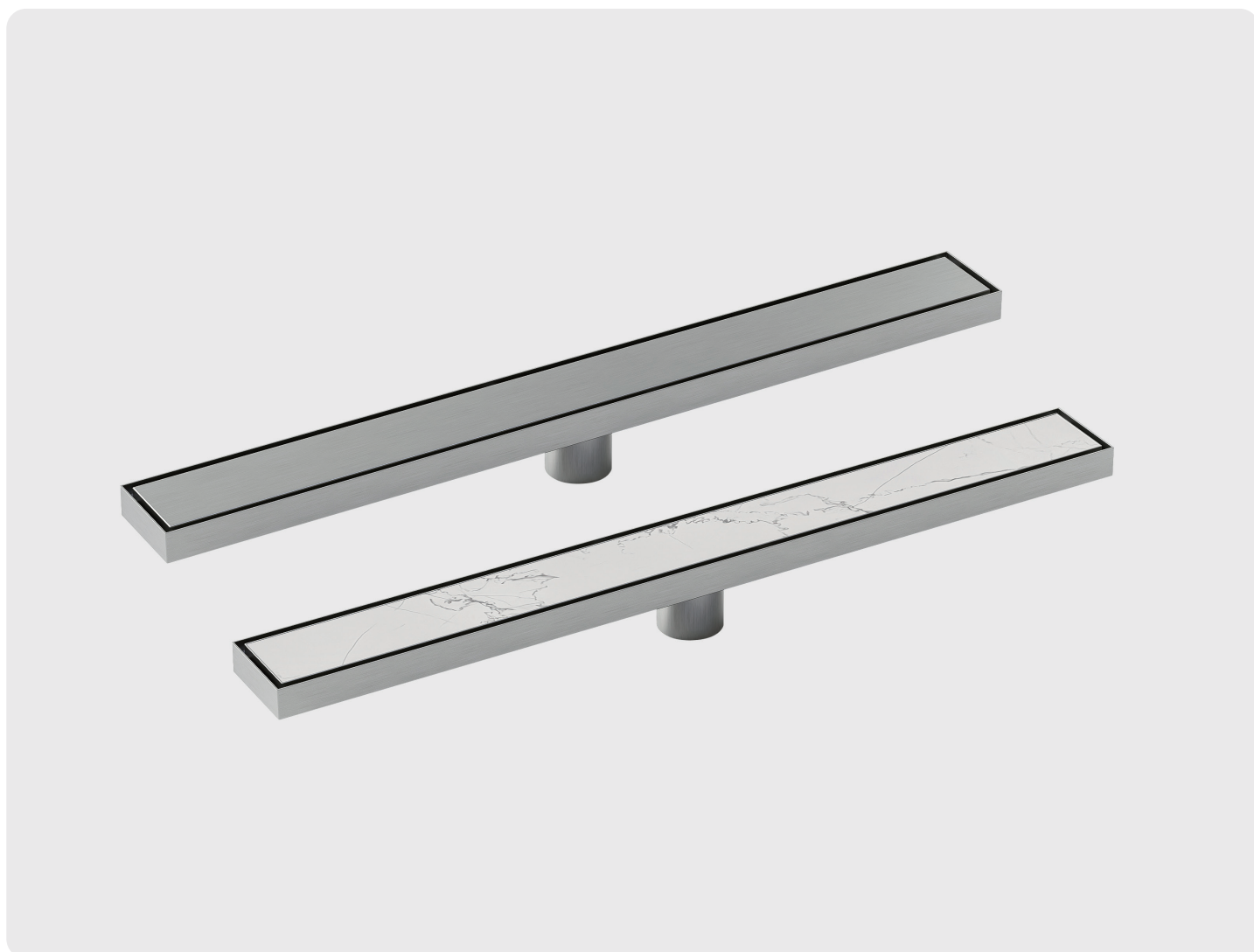

## VERSA CHANNEL DRAIN 700

Model:	2-FCTI700	Warranty:	10 years
Size:	700 x 75 x 25	Note:	Features reversible design, allowing metal insert & tile insert options, includes 80mm puddle flange & hair catcher
Material:	304 Stainless Steel		
Waste outlet:	50mm Ø		

### Colour Range:

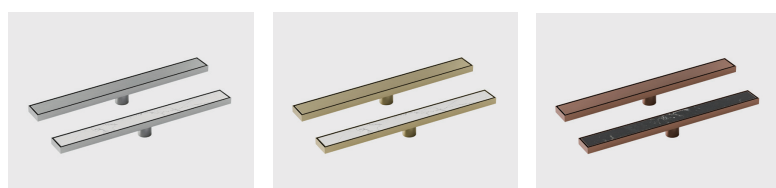

Brushed Stainless

Brushed Brass

Brushed Copper



Brushed Bronze

Matte Black

Gunmetal

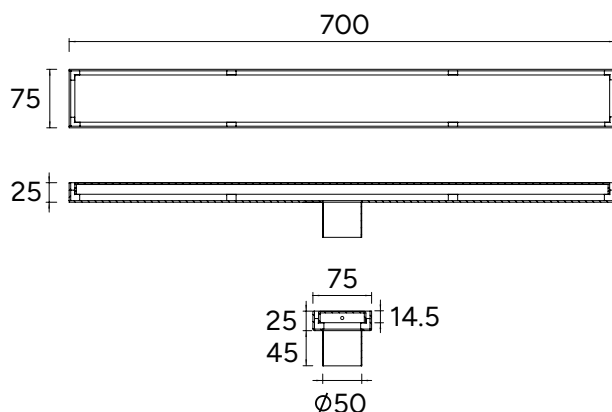

Note: All measurements shown are in millimetres. Sizes are nominal.

Distributed by:

CODE  
INTERIORS

In accordance with our continuous product development, Code interiors sizes and specifications outlined in these specifications are subject to change without notice. Information detailed in this document represents the actual product available at the time of printing this sheet. For the latest version of this technical sheet please visit [www.codeinteriors.co.nz](http://www.codeinteriors.co.nz) or contact your nearest stockist to confirm any questions prior to purchase.

[sales@codeinteriors.co.nz](mailto:sales@codeinteriors.co.nz) | 09 973 4066 | [www.codeinteriors.co.nz](http://www.codeinteriors.co.nz)