

PRODUCT SPECIFICATION SHEET



SHOWER GLASS PANEL 1050

Model: CSC-G-1050
 Size: 1050W*2058H
 Wall Profile: Stainless Steel
 Glass: 4+4mm Laminate Tempered Glass
 Nano clear easy clean: Yes

Installation: Universal LH or RH (Pillar LH only)
 Warranty: 10 years
 Weight: 47Kg
 Note: Glass compliance to NZ safety standards AS/NZS 2208:1996

Core range colours:



Chrome

Brushed Nickel

Matt Black



Brushed Brass

Brushed Bronze

Gun Metal

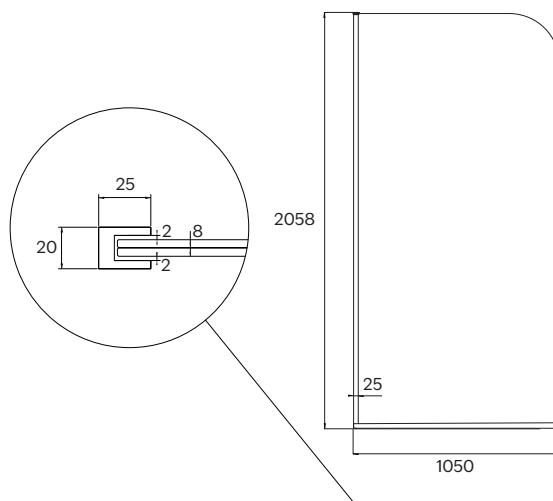

Note: All measurements shown are in millimetres. Sizes are nominal.

Distributed by:

CODE
INTERIORS

In accordance with our continuous product development, Code interiors sizes and specifications outlined in these specifications are subject to change without notice. Information detailed in this document represents the actual product available at the time of printing this sheet. For the latest version of this technical sheet please visit www.codeinteriors.co.nz or contact your nearest stockist to confirm any questions prior to purchase.

sales@codeinteriors.co.nz | 09 973 4066 | www.codeinteriors.co.nz