

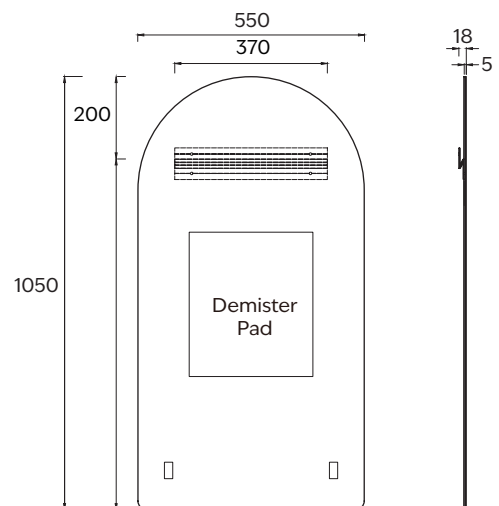

## REFLEX ARCH MIRROR 550X1050

Model: CM-21-A1050  
Size: 550\*1050\*18  
Demister Pad: Yes  
IP Rating: IP65  
Warranty: 5 years

Weight: 11Kg



Note: All measurements shown are in millimetres. Sizes are nominal.



## REFLEX ARCH MIRROR 850X950

Model: CM-21-A850  
Size: 850\*950\*18  
Demister Pad: Yes  
IP Rating: IP65  
Warranty: 5 years

Weight: 10Kg

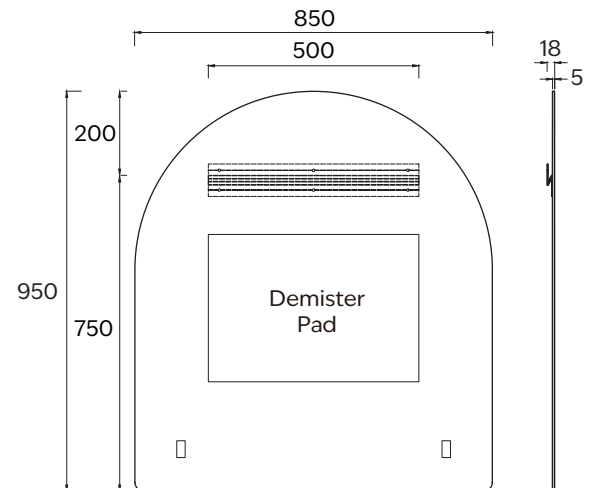

Note: All measurements shown are in millimetres. Sizes are nominal.